



# NTH 3000-PH63

Acid condensate neutralizer with pump

## Into the box



Neutralizer  
mm 700 x 400 x H 320



Neutralizer granular refill  
Neutralkit



A control unit activates the pump through probes. An external system signals the station status and through this system allows manual tests on the working pump.

## Max 2600 kW

The neutralizer station of acid condensate with the pump is easy to be installed and allows the evacuation of condensate when it is not possible to discharge for gravity. The strong structure of the tank and the pump NTH3000 make this product reliable. The recharge and the maintenance are easy and fast.



Code	Article	Description
SP040PH3001	NTH 3000-PH63	Neutralizer station with pump
SPN0409063	NEUTRALKIT63	Granular Neutralkit

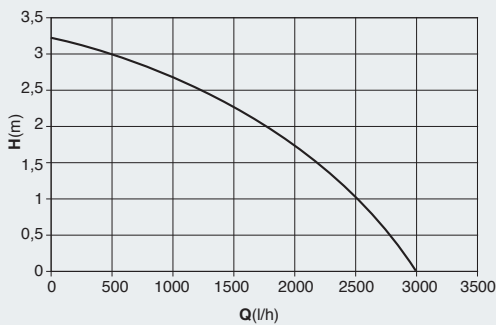

## Technical data

- Max generator power .....2600 kW
- Max flow ..... 260 l/h
- Minimum inlet head..... 130 mm
- Voltage ..... 220V - 50Hz
- Absorption..... .60W
- Max head ..... 3,2 m
- Max flow rate ..... 3.000 l/h
- Dimensions..... 70x40x32cm
- Weight ..... 40 Kg
- Non return valve included ..... 1/2"
- Long-life at max flow..... 1100 h

Ref.	Description
1	Inlet connection G 1"¼
2	Neutralizer granular refill Neutralkit
3	Inlet filter T Shape
4	Neutralizer box
6	Outlet connection G ½"
7	Submerged pump

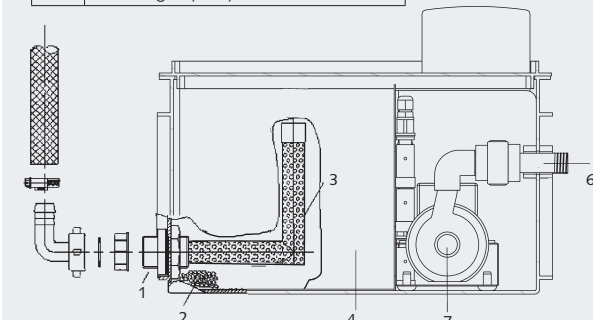

## Example of installation

1- wall-mounted or floor standing boilers

The station has to be installed near the boiler and in horizontal position. The inlet pipe to the station will follow the guide lines given by our technical office

