



**Models • Modelli**  
**AAD-10 • AAR-10S • AAT-10**

**ENGLISH**

This instruction sheet provides you with the information required to safely own and operate your product. Retain these instructions for future reference. The product you have purchased is of the highest quality workmanship and material, and has been engineered to give you long and reliable service. This product has been carefully tested, inspected, and packaged to ensure safe delivery and operation. Please examine your item(s) carefully to ensure that no damage occurred during shipment. If damage has occurred, please contact the place of purchase. They will assist you in replacement or repair, if required.

**READ THESE INSTRUCTIONS CAREFULLY BEFORE ATTEMPTING TO INSTALL, OPERATE, OR SERVICE YOUR PRODUCT. KNOW THE PRODUCT'S APPLICATION, LIMITATIONS, AND POTENTIAL HAZARDS. PROTECT YOURSELF AND OTHERS BY OBSERVING ALL SAFETY INFORMATION. FAILURE TO COMPLY WITH THESE INSTRUCTIONS COULD RESULT IN PERSONAL INJURY AND/OR PROPERTY DAMAGE!**

**CE DECLARATION OF CONFORMITY**

We, Steelpumps, declare that our pumps AAD, AAR & AAT with pump type and serial number as shown on the nameplate are constructed in accordance with Directives 2006/95/EC and 89/336/EEC and assume full responsibility for conformity with the standards laid down therein.

**DESCRIPTION**

Your Steelpumps peristaltic condensate pump is designed as a fully automatic condensate removal system for the water dripping off an air conditioner evaporator coil. The pump is not for continuous use applications. The pump you have purchased is a small but powerful drain pump for the positive displacement of condensate from fan coils and air conditioners. The design of this pump allows the air handler to be located away from gravity water drains since the condensate can be pumped to a common drain a distance away. The peristaltic pump is designed to remove condensation from fan coil, wall-mount, ceiling and cassette air conditioning equipment.

**SAFETY GUIDELINES**

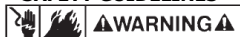

**SHUT OFF ELECTRICAL POWER AT FUSE BOX BEFORE ATTEMPTING TO SERVICE, DISCONNECT, CONNECT OR REMOVE ANY COMPONENT!**

1. This pump is not to be used to pump flammable or explosive fluids such as gasoline, fuel oil, kerosene, etc. Do not use this pump in explosive atmospheres.
2. Do not handle pump with wet hands or when standing on a wet, damp surface or when standing in water.
3. In any installation where property damage and/or personal injury might result from an inoperative or leaking pump due to power outages, discharge line blockage, or any other reason, a backup system(s) and/or alarm should be used.
4. Support pump and piping when assembling and when installed. Failure to do so may cause piping to break, pump to fail, motor bearing failures, etc; or may cause the pump to malfunction.
5. Place pump in an area where there is no danger of ingress of water.

**SPECIFICATIONS**

Maximum suction head: 2m (6.5 ft)  
 Maximum delivery head: 14m (49 ft)  
 Maximum ambient temperature: 50°C (122°)

**PRE-INSTALLATION**

1. Check the pump label for proper voltage and frequency required. Do not connect to voltage and frequency other than that shown.
2. It is recommended to use 1/4" I.D. or 6 mm I.D. tubing for both the inlet and outlet. Inlet tubing is connected to the inlet fitting identified by an upward arrow. Outlet or discharge tubing is connected to the outlet fitting identified by a downward arrow.
3. Make sure the transparent cover is closed before operating.

**INSTALLATION**

**Pump Mounting Installation:**

The pump can be mounted adjacent, below or above (but not more than 2m above) the condensate water source. For best results, mount the pump with the hose connections facing down as shown in Figure 1B

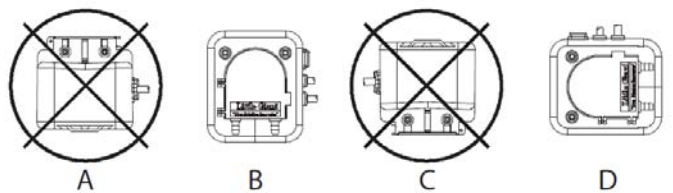

**FIGURE 1**

The pump may also be positioned on any side, but not placed rotor downward (Figure 1C) or upward (Figure 1A). Connect 6.0mm or 1/4" tubing (not provided) to the pump intake indicated by the arrow pointing upward on the transparent cover. Position the other end of the intake tube in the drip tray drain hose and seal it accordingly or place the intake tube in the drip tray (Figure 2). Be careful not to twist, kink, or collapse the tubing. Run a length of 6.0mm or 1/4" tubing (not provided) from the discharge of the pump to a gravity drain. Refer to Figure 2 for maximum vertical and horizontal discharge capabilities.

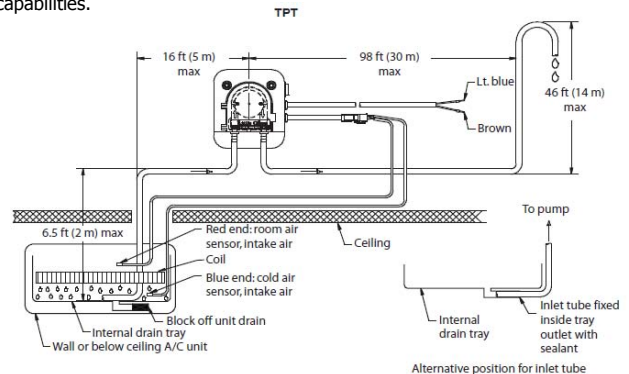

**FIGURE 2**

**CAUTION:** Be certain that there are no sharp bends or kinks in the suction and discharge tubing. Keep all tubing and cables clear of moving parts in the air handler. If using Ty-raps to secure tubing, be certain the Ty-rap does not collapse tubing.

**Collection Reservoir Installation (R Series only):**

Locate the float reservoir in a suitable position below the bottom level of the drip tray of the air conditioner. Be certain that the reservoir is within (+/-) 15 degrees of being level. Optimum performance is achieved when the reservoir is level. If the reservoir is not mounted properly, the float mechanism may not function properly and may overflow.

Attach the 13mm (1/2") tubing (provided) to the reservoir intake and the drip tray outlet or drain hose. Be certain to support the reservoir when attaching tubing and make sure the tubing is not twisted, kinked or collapsed when reservoir is in place. Connect the long 4 x 6 mm (5/32") tubing (provided) to the discharge of the reservoir marked "PUMP". Connect the other end of the 4 x 6 mm (5/32") tubing (not provided) to the provided 4 x 6 mm adapter. Use a short piece of 6 mm or 1/4" tubing (not provided) to connect the 4 x 6 mm adapter to the pump inlet fitting identified by an upward arrow. Connect the short 4 x 6 mm (5/32") tubing (provided) to the outlet of the reservoir marked "VENT". The free end of the tubing must be directed upward above the drip tray to prevent overflow. Be certain the tubing is not twisted, kinked or collapsed when installed.

**ELECTRICAL CONNECTIONS**



**SHUT OFF ELECTRICAL POWER AT FUSE BOX BEFORE MAKING ANY CONNECTIONS. ALL WIRING MUST COMPLY WITH LOCAL CODES. CHECK THE PUMP LABEL FOR PROPER VOLTAGE REQUIRED. DO NOT CONNECT TO VOLTAGE OTHER THAN THAT SHOWN.**

**AAD Series** (compressor or cooling signal) - Connect the brown wire to the main phase (line), the blue wire to the neutral phase (common). The pump must not be connected to a switched line. Electricity should always be provided on this line. Connect the orange wire to the compressor or cooling signal (Figure 3). When the compressor engages, a 230V supply voltage will be sent to start the pump. When the compressor stops operating, the pump will not stop. The pump is programmed to continue operating for another 5 minutes to collect any residual condensate before stopping.

**Note:** The compressor or cooling signal neutral phase (common) needs to be the same neutral phase (common) that is used to supply power to the controller.

**AAT Series** (temperature signal) **FOR PROPER PUMP OPERATION, PLEASE FOLLOW THESE INSTRUCTIONS:** Connect the brown wire to the main phase (line) and the blue wire to the neutral phase (common) (Figure 2). Make sure power is off when connecting the temperature sensor to the pump. Connect the sensor cable to the pump by connecting the 4-prong plug to the corresponding

cable on the pump. There are 2 lead wires with sensors at the ends; one lead has a blue end and the other has a red end. Affix the wire with the blue sensor to the "cold" or "air out" side of the evaporator coil and the wire with the red sensor to the "hot" or "air in" side of the evaporator coil (Figure 2).

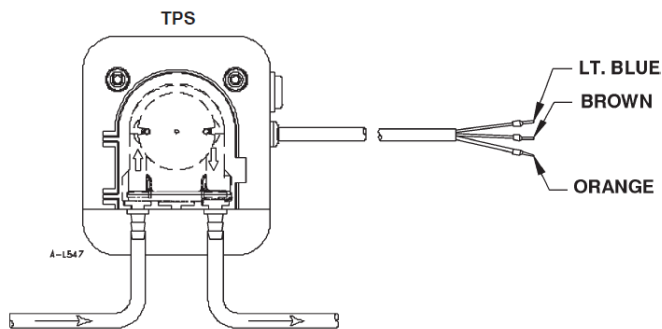

FIGURE 3

The pump will start when a temperature difference of 5°C (9°F) is reached between the blue and red sensor. As long as the difference in temperature is more than 5°C (9°F), the pump will operate. When the difference in temperature is less than 5°C (9°F), the current cuts off and the pump will continue to operate for 5 minutes then stop. **NOTE:** Never put the sensors directly into water or condensate. Do not attach the sensors to the refrigeration piping. Do not leave the sensors loose in the open air.

**AAR Series** (reservoir control tank) - Connect the brown wire to the main phase (line) and the blue wire to the neutral phase (common) (Figure 4). Make sure power is off when connecting the reservoir to the pump. Connect the cable from the reservoir tank to the pump by connecting the 4-prong plug to the corresponding cable on the pump.

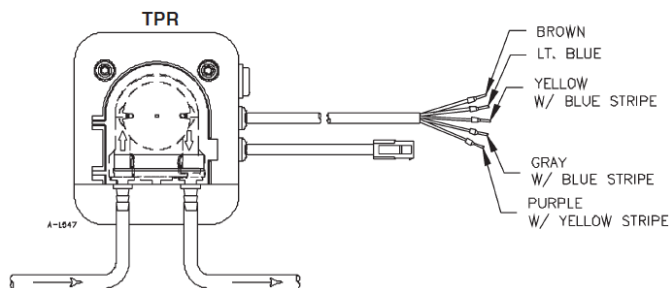

FIGURE 4

**AAR Series (overflow/alarm connection)** - Connect the cables as described below to obtain the desired response:

**C and NC** - When water rises, the circuit opens to turn off the compressor and prevents overflow by connecting the gray with the blue stripe wire and the yellow with the blue stripe wire. (Figure 4)

**C and NO** - When water rises, the circuit closes to activate a bell or alarm (not provided) by connecting the gray with the blue stripe wire and the purple with the yellow stripe wire (Figure 4).

The rating for the alarm circuit is 200VDC, 1 amp max., and 15 watts max.

**Pump to Power Supply:**

Brown - main phase (line)

Blue - neutral phase (common)

After electrical connections have been made, check the pump for proper operation. Press the test switch to determine if pump operates properly.

**SERVICE INSTRUCTIONS**



DISCONNECT THE PUMP FROM THE POWER SOURCE BEFORE SERVICING OR REMOVING ANY COMPONENTS.

**Inspect and clean the reservoir tank whenever the air conditioner is serviced or at the beginning of the season.**

**Reservoir:** Carefully remove the reservoir cover by gently flexing the locking tab.

Be careful not to damage the o-ring. Remove the mesh screen and rinse it under running water. Remove any debris that may block the mesh. Use a damp cloth to remove dust or debris from the reservoir. When re-installing the float/magnet, be certain that the beveled edge of the float is up and the magnet is properly seated before reassembling the reservoir. Carefully hook the cover and then press it onto the tank until the spring tab snaps in place. Use care to make sure the o-ring is properly installed (that is, not twisted, torn, or otherwise out of its track.)

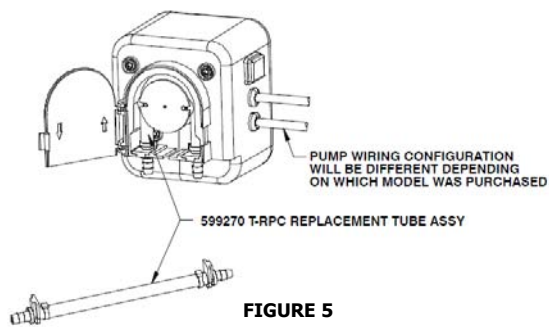

FIGURE 5

REPLACEMENT PARTS NOT SHOWN		
PART NO.	DESCRIPTION	USED ON MODEL
944322	TUBE NATURAL RUBBER	TPR
153781	RESERVOIR ASSEMBLY	TPR
944322	TEMP SENSOR ASSEMBLY	TPT

**Pump Tubing Replacement:**

1. Disconnect the pump from the power source.
2. Open the transparent cover.
3. To remove the pump tube, put the rotor in a vertical position, and remove the inlet side tubing from its left seat. Pull the tubing upward while manually rotating the rotor clockwise. Fully remove the tube from the right seat.
4. Apply a small amount of silicone grease to the new tube before installing it; this will help lubricate the tube. No other lubrication is required.
5. To install the pump tube, put the rotor in a horizontal position. Push the inlet side tube connector into the left seat, making sure it is fully inserted. While rotating the rotor clockwise, push the tubing into place. Once the tubing is moved into position, insert the outlet connector into the seat of the right side.
6. Close the transparent front cover.

**Disposal of Product:**

Dispose of or recycle product properly, according to all relevant authorities.